

Allen Razorback[®] Work Bridge - WB12

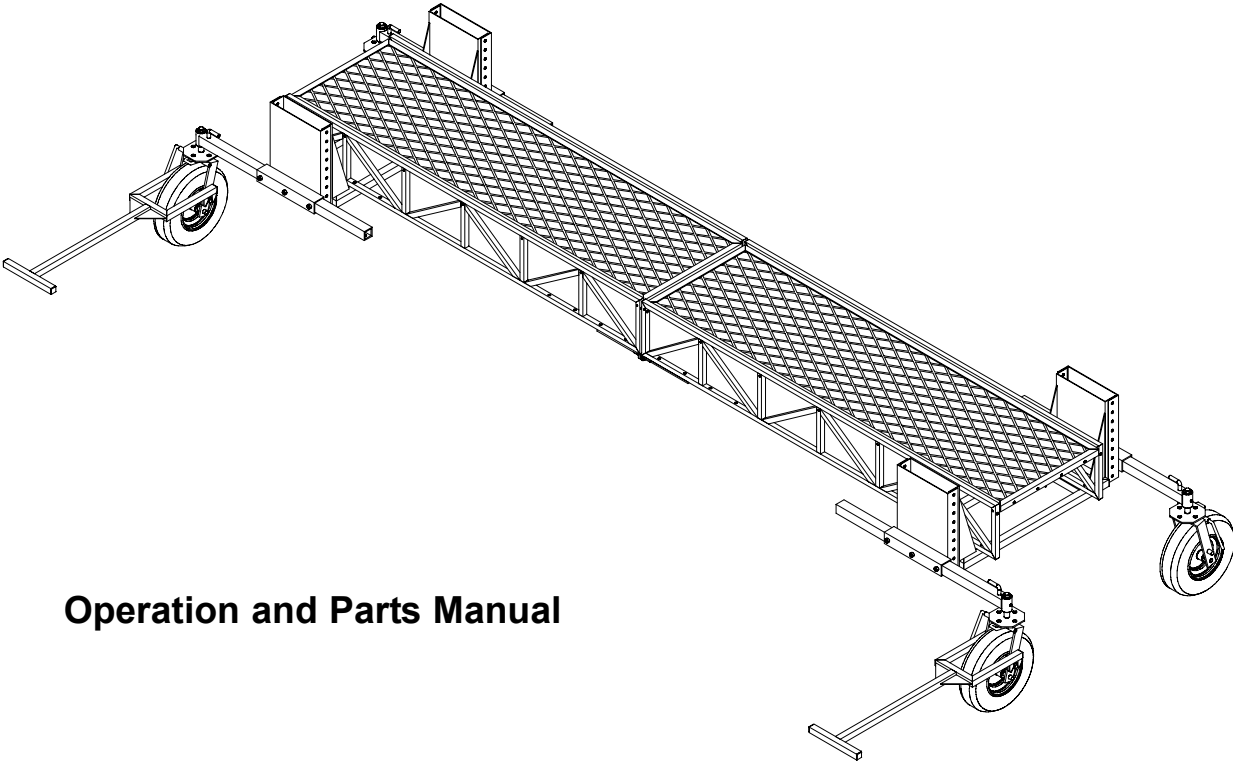

Operation and Parts Manual

Technical Data

Construction	Sq. Tube Welded Frame
Section Lengths2', 5', and 7-1/2' Interchangeable
Size24" wide work surface - 12" deep
Min/Max Lengths5' - 65'
Decking	Expanded Metal
Height	From top of deck to slab - 28"
.....	Optional - Vertically adjustable end frames from 16" to 36"
Wheels	Mounted in 360° bearing swivels with 4-position directional lock.
.....	Pneumatic tires with individual brakes are standard. Flanged
.....	style wheels for forms, or cupped steel wheels for riding pipe
.....	rails are available as options. Special sliding wheel brackets
.....	allow variable spacing between work bridge and wheels.

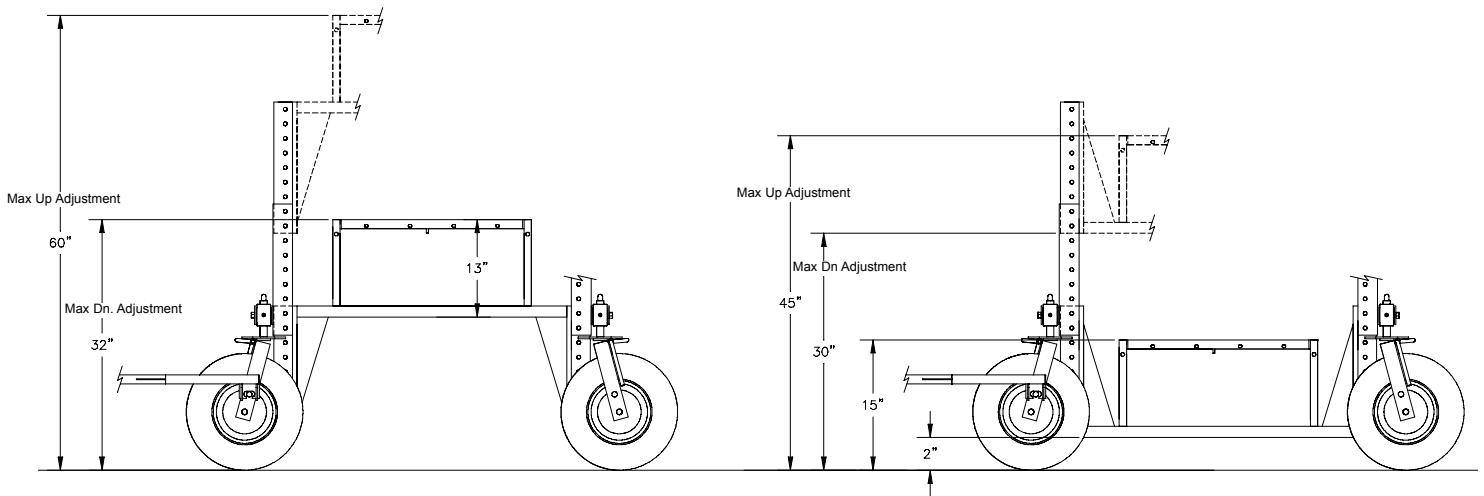

SECTION 2A PARTS

ILL.	PART #	DESCRIPTION	QTY.
1.	.221303	.TOP DECK - 2' FRAME	1
	.043604	.TOP DECK - .25m FRAME (METRIC)	1
2.	.221300	.SIDE FRAME - 2' FRAME	2
	.043605	.SIDE FRAME - .25m FRAME (METRIC)	2
3.	.221304	.TOP DECK - 5' FRAME	1
	.043607	.TOP DECK - .75m FRAME (METRIC)	1
4.	.221301	.SIDE FRAME - 5' FRAME	2
	.043608	.SIDE FRAME - .75m FRAME (METRIC)	2
5.	.221305	.TOP DECK - 7-1/2' FRAME	1
	.043610	.TOP DECK - 2m FRAME (METRIC)	1
6.	.221302	.SIDE FRAME - 7-1/2' FRAME	2
	.043611	.SIDE FRAME - 2m FRAME (METRIC)	2
	.043613	.TOP DECK - 3.75m FRAME (METRIC)	1
	.043614	.SIDE FRAME - 3.75m FRAME (METRIC)	2
7.	.010073	.BOLT, 1/2 x 2-1/2	2
8.	.010847	.CROSS MEMBER	2
9.	.221109	.HINGE, YOKE ASSEMBLY	1
10.	.010125	.HINGE PIN	1
11.	.010131	.COTTER PIN, 1/16 x 1	1
12.	.010089	.BOLT, 1/2 x 1-1/2	4
13.	.221106	.HINGE, EYE ASSEMBLY	1
14.	.010106	.NUT, 1/2"	?
15.	.010067	.BOLT, 1/2 x 1	4
16.	.221122	.OUTER WHEEL ADJUSTMENT BRACKET	2
17.	.221257	.TELESCOPE TUBE ASSEMBLY	4
18.	.010075	.BOLT, 1/2 x 3	12
19.	.221306	.UNDER CARRIAGE ASSEMBLY	2
20.	.221128	.YOKE	4
21.	.010158	.CUP WHEEL F/ PIPE RAILS	4
22.	.010159	.FLANGE WHEEL F/ FORMS	4
23.	.010157	.AXLE	4
24.	.010148	.WASHER	8
25.	.010133	.COTTER PIN, 3/16 x 2	8
26.	.221258	.YOKE, PNEUMATIC TIRE	4
27.	.221058	.TIRE & WHEEL ASSEMBLY	4
28.	.010147	.AXLE	4
29.	.221029	.TIRE AND YOKE ASSEMBLY	4

ASSEMBLIES:

1.	.020462	.END FRAME KIT	1
	.010067	.BOLT, 1/2-13 x 1	44
	.010077	.BOLT, 1/2-13 x 3 1/2	8
	.010093	.LOCKWASHER, 1/2	8
	.010106	.NUT, HEX 1/2-13Q	52
	.221122	.OUTER WHEEL ADJUSTMENT BRACKET	4
	.221306	.UNDER CARRIAGE ASSEMBLY	2
2.	.020492	.WORKBRIDGE, 2' SECTION	1
	.010023	.BOLT, 5/16-18 x 1 3/8	14
	.010037	.BOLT, 3/8-16 x 1 1/4	4
	.010073	.BOLT, 1/2-13 x 2 1/2	6
	.010075	.BOLT, 1/2-13 x 3	2
	.010083	.FLATWASHER, 3/8	16
	.010090	.LOCKWASHER, 5/16	14
	.010091	.LOCKWASHER, 3/8	4
	.010093	.LOCKWASHER, 1/2	8
	.010100	.NUT, HEX 5/16-18	14
	.010102	.NUT, HEX 3/8-16	4

SECTION 2A PARTS

2. Cont'd	.020492	WORKBRIDGE, 2' SECTION	1
	.010106	NUT, HEX 1/2-13	8
	.010125	PIN, CLEVIS	2
	.010847	CROSS BRACE	1
	.010711	HAIR PIN, .120 x 1	2
	.221108	HINGE, MALE EYE	2
	.221109	HINGE, FEMALE EYE	2
	.221300	RAIL, SIDE 2'	2
	.221303	DECK, TOP 2'	1
3.	.043606	WORKBRIDGE, .25m SECTION	1
	.010023	BOLT, 5/16-18 x 1 3/8	14
	.010037	BOLT, 3/8-16 x 1 1/4	4
	.010073	BOLT, 1/2-13 x 2 1/2	6
	.010075	BOLT, 1/2-13 x 3	2
	.010083	FLATWASHER, 3/8	16
	.010090	LOCKWASHER, 5/16	14
	.010091	LOCKWASHER, 3/8	4
	.010093	LOCKWASHER, 1/2	8
	.010100	NUT, HEX 5/16-18	14
	.010102	NUT, HEX 3/8-16	4
	.010106	NUT, HEX 1/2-13	8
	.010125	PIN, CLEVIS	2
	.010847	CROSS BRACE	1
	.010711	HAIR PIN, .120 x 1	2
	.221108	HINGE, MALE EYE	2
	.221109	HINGE, FEMALE EYE	2
	.043605	RAIL, SIDE .25m	2
	.043604	DECK, TOP .25m	1
4.	.020493	WORKBRIDGE, 5' SECTION	1
	.010023	BOLT, 5/16-18 x 1 3/8	14
	.010037	BOLT, 3/8-16 x 1 1/4	4
	.010073	BOLT, 1/2-13 x 2 1/2	6
	.010075	BOLT, 1/2-13 x 3	2
	.010083	FLATWASHER, 3/8	16
	.010090	LOCKWASHER, 5/16	14
	.010091	LOCKWASHER, 3/8	4
	.010093	LOCKWASHER, 1/2	8
	.010100	NUT, HEX 5/16-18	14
	.010102	NUT, HEX 3/8-16	4
	.010106	NUT, HEX 1/2-13	8
	.010125	PIN, CLEVIS	2
	.010847	CROSS BRACE	1
	.010711	HAIR PIN, .120 x 1	2
	.221108	HINGE, MALE EYE	2
	.221109	HINGE, FEMALE EYE	2
	.221301	RAIL, SIDE 5'	2
	.221304	DECK, TOP 5'	1
5.	.043609	WORKBRIDGE, .75m SECTION	1
	.010023	BOLT, 5/16-18 x 1 3/8	14
	.010037	BOLT, 3/8-16 x 1 1/4	4
	.010073	BOLT, 1/2-13 x 2 1/2	6
	.010075	BOLT, 1/2-13 x 3	2
	.010083	FLATWASHER, 3/8	16
	.010090	LOCKWASHER, 5/16	14
	.010091	LOCKWASHER, 3/8	4
	.010093	LOCKWASHER, 1/2	8
	.010100	NUT, HEX 5/16-18	14
	.010102	NUT, HEX 3/8-16	4

SECTION 2A PARTS

5.Cont'd	.043609	.WORKBRIDGE, .75m SECTION	.1
	.010106	.NUT, HEX 1/2-13	.8
	.010125	.PIN, CLEVIS	.2
	.010847	.CROSS BRACE	.1
	.010711	.HAIR PIN, .120 x 1	.2
	.221108	.HINGE, MALE EYE	.2
	.221109	.HINGE, FEMALE EYE	.2
	.043608	.RAIL, SIDE .75m	.2
	.043607	.DECK, TOP .75m	.1
6.	.020494	.WORKBRIDGE, 7-1/2' SECTION	.1
	.010023	.BOLT, 5/16-18 x 1 3/8	.14
	.010037	.BOLT, 3/8-16 x 1 1/4	.4
	.010073	.BOLT, 1/2-13 x 2 1/2	.6
	.010075	.BOLT, 1/2-13 x 3	.2
	.010083	.FLATWASHER, 3/8	.16
	.010090	.LOCKWASHER, 5/16	.14
	.010091	.LOCKWASHER, 3/8	.4
	.010093	.LOCKWASHER, 1/2	.8
	.010100	.NUT, HEX 5/16-18	.14
	.010102	.NUT, HEX 3/8-16	.4
	.010106	.NUT, HEX 1/2-13	.8
	.010125	.PIN, CLEVIS	.2
	.010847	.CROSS BRACE	.1
	.010711	.HAIR PIN, .120 x 1	.2
	.221108	.HINGE, MALE EYE	.2
	.221109	.HINGE, FEMALE EYE	.2
	.221302	.RAIL, SIDE 7-1/2'	.2
	.221305	.DECK, TOP 7-1/2'	.1
7.	.043612	.WORKBRIDGE, 2m SECTION	.1
	.010023	.BOLT, 5/16-18 x 1 3/8	.14
	.010037	.BOLT, 3/8-16 x 1 1/4	.4
	.010073	.BOLT, 1/2-13 x 2 1/2	.6
	.010075	.BOLT, 1/2-13 x 3	.2
	.010083	.FLATWASHER, 3/8	.16
	.010090	.LOCKWASHER, 5/16	.14
	.010091	.LOCKWASHER, 3/8	.4
	.010093	.LOCKWASHER, 1/2	.8
	.010100	.NUT, HEX 5/16-18	.14
	.010102	.NUT, HEX 3/8-16	.4
	.010106	.NUT, HEX 1/2-13	.8
	.010125	.PIN, CLEVIS	.2
	.010847	.CROSS BRACE	.1
	.010711	.HAIR PIN, .120 x 1	.2
	.221108	.HINGE, MALE EYE	.2
	.221109	.HINGE, FEMALE EYE	.2
	.043611	.RAIL, SIDE 2m	.2
	.043610	.DECK, TOP 2m	.1
8.	.043615	.WORKBRIDGE, 3.75m SECTION	.1
	.010023	.BOLT, 5/16-18 x 1 3/8	.14
	.010037	.BOLT, 3/8-16 x 1 1/4	.4
	.010073	.BOLT, 1/2-13 x 2 1/2	.6
	.010075	.BOLT, 1/2-13 x 3	.2
	.010083	.FLATWASHER, 3/8	.16
	.010090	.LOCKWASHER, 5/16	.14
	.010091	.LOCKWASHER, 3/8	.4
	.010093	.LOCKWASHER, 1/2	.8
	.010100	.NUT, HEX 5/16-18	.14
	.010102	.NUT, HEX 3/8-16	.4

SECTION 2A PARTS

8. Cont'd	.043615	.WORKBRIDGE, 3.75m SECTION	.1
	.010106	.NUT, HEX 1/2-13	.8
	.010125	.PIN, CLEVIS	.2
	.010847	.CROSS BRACE	.1
	.010711	.HAIR PIN, .120 x 1	.2
	.221108	.HINGE, MALE EYE	.2
	.221109	.HINGE, FEMALE EYE	.2
	.043614	.RAIL, SIDE 3.75m	.2
	.043613	.DECK, TOP 3.75m	.1
9.		.ACCESORIES FOR WORKBRIDGE	
	.110100	.WINCH LEFT HAND DL2500 W/ 100' CABLE	.1
	.018670	.WINCH RIGHT HAND DL2500 W/ 100' CABLE	.1
	.043616	.BRACKET, DL2500 WINCH F/ WORKBRIDGE	.2

SECTION 2A PARTS

